



ColorMix 150 AT wash

Technical Specification

- CDM-SA/T 150W/942 discharge lamp (150W, 12.900 lumens, G-12, 4200K, 6000 hour life)
- Colour wheel with 11 dichroic colours + open white, rainbow effect in both directions
- Soft-edge output from 80mm PC lens, 21° beam angle
- Separate shutter for black-out and strobe-effect 1-9 flashes per sec.
- Smooth mechanical dimmer
- Silent fan cooling
- Addressing, personality setting and effects calibration via 4-digit LED control panel
- Stand alone and Master/Slave operation
- On-board programming, 3 freely programmable programs (99 steps each)
- built-in microphone for music trigger in stand alone (master-slave) operation
- DMX channels: 4 protocol modes

Technical Specification

- CDM-SA/T 150W/942 discharge lamp (150W, 12.900 lumens, G-12, 4200K, 6000 hour life)
- Colour wheel with 11 dichroic colours + open white, rainbow effect in both directions
- Gobo wheel: 7 indexable rotating (metal, glass & dichroic) + open position, continuous rotation in both directions
- Multi layer coated 3-lens focus objective unit
- Standard 19,2° manually focused beam angle
- Separate shutter for black-out and strobe-effect 1-9 flashes per sec.
- Silent fan cooling
- Addressing, personality setting and effects calibration via 4-digit LED control panel
- Stand alone and Master/Slave operation
- On-board programming, 3 freely programmable programs (99 steps each)
- Built-in microphone for music trigger in stand alone (master-slave) operation
- DMX channels: 4 protocol modes

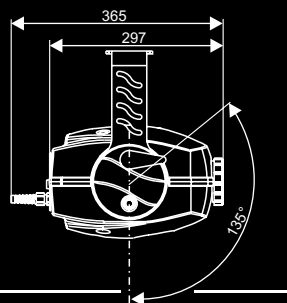
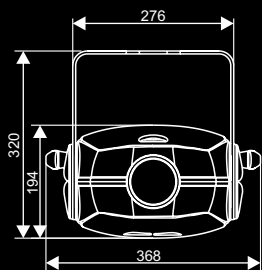
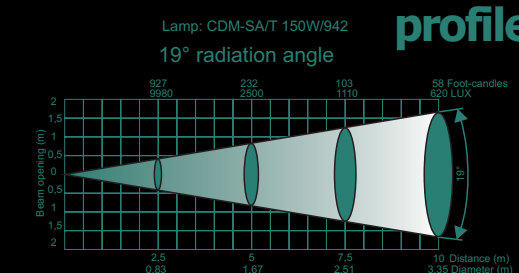
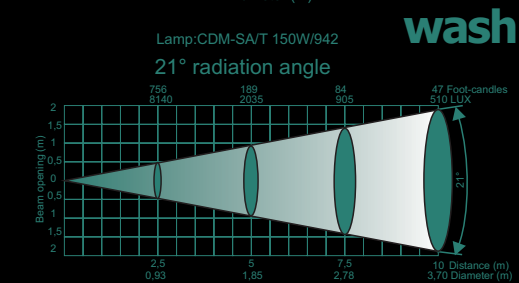
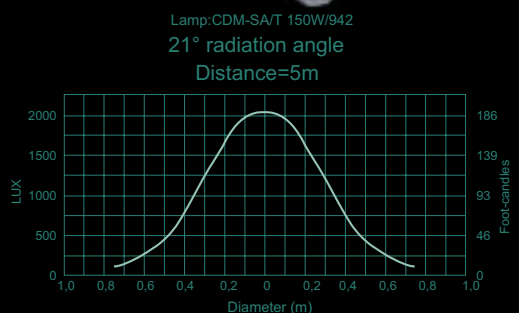

colormixes





ColorMix 550 AT

Technical Specification

- MSR 575/2 discharge lamp (575W, 7200K, 750hr life)
- Remote lamp On/Off
- Manually adjustable 200mm fresnel lens with 7°- 26° Zoom
- Full CMY colour mixing
- Separate shutter for black-out and Variable strobing (max 10 flashes per sec.)
- Dimmer unit allowing very smooth micro-step driven dimming
- Preprogrammed Colour Macros
- Variable/random pulse effects
- Selectable 8 or 16 bit resolution
- Addressing, personality setting and effects calibration via 4-digit LED control panel

ColorMix 575 AT

Technical Specification

- MSR 575/2 discharge lamp (575W, 7200K, 750hr life)
- Remote lamp On/Off
- Motorized 200mm fresnel lens with 7°- 26° Zoom
- Full CMY colour mixing
- Colour wheel with 4 discrete filters + open, 3200K and 5600K CTF, UV filter
- Colour wheel continuous rotation (rainbow effect) in both directions
- Beam shape adjustment 0-180°, frost filter
- Separate shutter for black-out and Variable strobing (max 10 flashes per sec.)
- Dimmer unit allowing very smooth micro-step driven dimming
- Preprogrammed Colour Macros
- Variable/random pulse effects
- Selectable 8 or 16 bit resolution
- Addressing, personality setting and effects calibration via 4-digit LED control panel
- 11/14 DMX control channels

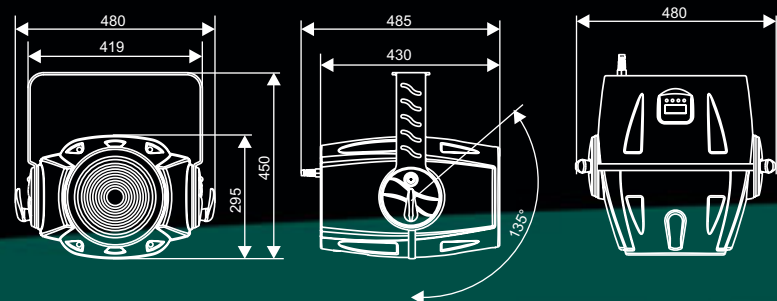
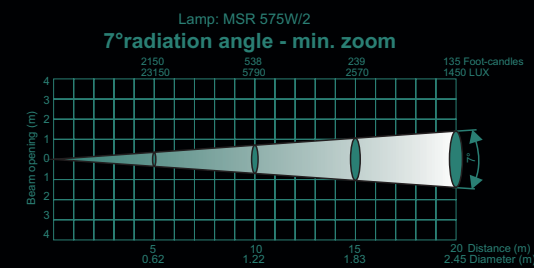
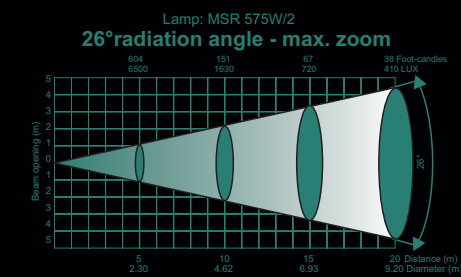
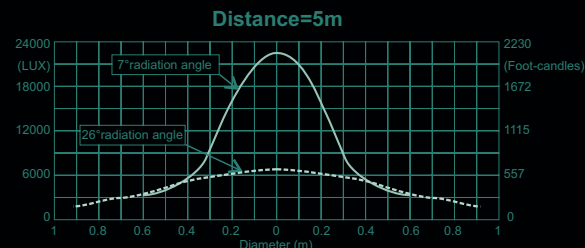

ColorMix 550/575 AT



ColorMix 240 AT

Technical Specification

- MSD 250/2 discharge lamp (250W, 18.000 lumens, GY-9.5, 8500K, 2000hr life)
- Remote lamp On/Off via DMX
- Manual zoom with beam angle ranging from 8° to 22° via 150 mm Fresnel lens
- Smooth dichroic CMY colour mixing system
- Separate shutter for black-out and Variable strobing (1-10 flashes per sec.)
- Dimmer unit allowing very smooth micro-step driven dimming
- Pre-programmed Dimmer and Strobe Macros with variable/random pulse effect
- Remotely controllable Fan speed
- Addressing, personality setting and effects calibration via 4-digit LED control panel
- Stand alone and Master/Slave operation, On-board programming
- 3 freely programmable programs (99 steps each)
- Built-in microphone for music trigger in stand alone (master-slave) operation
- DMX channels: 2 protocol modes (8/11 channels)

ColorMix 250 AT

Technical Specification

- MSD 250/2 discharge lamp (250W, 18.000 lumens, GY-9.5, 8500K, 2000hr life)
- Remote lamp On/Off via DMX
- Manual zoom with beam angle ranging from 8° to 22° via 150 mm Fresnel lens
- Smooth dichroic CMY colour mixing system
- Colour wheel with Red, Green, Blue, 3200K and 5600K CTF, UV filter (black light) + open
- Colour wheel with continuous rotation (rainbow effect) in both directions
- Rotatable (0-180°), variable beam shaping, frost filter for softer beam effects
- Separate shutter for black-out and Variable strobing (1-10 flashes per sec.)
- Dimmer unit allowing very smooth micro-step driven dimming
- 4 -leaf barn door, rotatable plus or minus 90°
- Floor stand
- Pre-programmed Dimmer and Strobe Macros with variable/random pulse effect
- Remotely controllable Fan speed
- Addressing, personality setting and effects calibration via 4-digit LED control panel
- Stand alone and Master/Slave operation, On-board programming
- 3 freely programmable programs (99 steps each)
- Built-in microphone for music trigger in stand alone (master-slave) operation
- DMX channels: 2 protocol modes (10/11 channels)

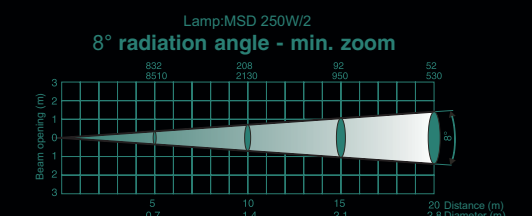
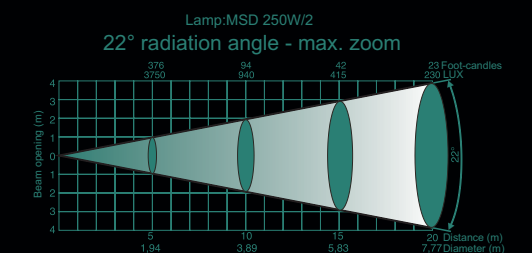
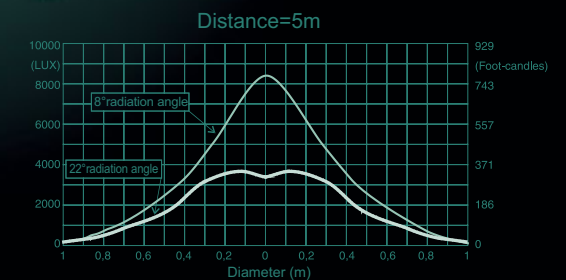

ColorMix 240 AT

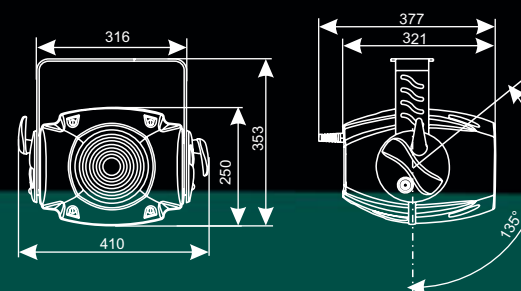

ColorMix 250 AT

